

MCRN2 RFID Reader/Writer

RS232/RS485, Buzzer & LED

The **MCRN2 RFID Reader** is a robust and flexible device designed for industrial environments. It supports both serial and USB interfaces, making integration easy across various systems. With a strong internal antenna and optional keyboard emulation via USB, it enables reliable card/tag reading and smooth operation in complex RFID setups.

Key features

- Interfaces RS232 / RS485**
 Provide reliable serial communication for industrial systems
- Wide operating voltage range**
 Can be integrated into **+12V** or **+24V** systems.
- Transponders**
 MIFARE® DESFire/Plus & Classic/Ultralight, NTAG, I-CODE
- Full NFC Support**
 Offers full NFC compatibility for contactless communication
- Integrated or external Antenna**
 Available with integrated or external antenna for flexible installation
- Secure Element**
 Hardware secure element for cryptographic key management and authentication.
- Powerful Antenna**
 Reads cards/tags up to 80mm away
- Bootloader**
 Includes bootloader for easy firmware updates

Ideal for

- EV-Charging Stations
- Access Control Systems
- Retail and POS Systems
- Library Management
- Industrial Automation
- Public Transportation
- Vending Machines
- Parking Management



Access Systems



Logistik Supply chain



EV-Charger



Industrial Automation



Time Tracing



Healthcare



Shop PoS



Public Transport



Parking



ATM



Library



Home Automation



Telemetry Systems

Technical Data

Operating Frequency	13.56 MHz	
Dimensions	59x71.5x9.10 mm	
MTBF	500.000h	
Interfaces	RS232 RS485 USB (Optional) Wi-Fi / BLE	
Supported Cards & Transponders	MIFARE®-DESFire/Plus MIFARE®-Classic/Ultralight NTAG I-Code	
Antenna	Integrated (Optional) External	
Temperature	-30°C to +85 °C	
Relative Air Humidity	5% up to 95% (non-condensing)	
Power Supply	+7V to +60V DC Or USB Bus	
Current Consumption	~100 mA	
Weight	20 g	
Supported Standards	ISO14443A/B ISO15693	
Certifications	USA Europe/UK	FCC 47 CFR Part 15 CE/RED
Compliances	EMC Environment	EN 301489 EN 55022 EN 300330 RED 2014/53/EU RoHS Compliance REACH 1907/2006

Dimension

The following views illustrate the precise dimensions and physical layout of the **MCRN2 RFID Reader/Writer** designed for seamless integration into various environments. All measurements are in millimeters.

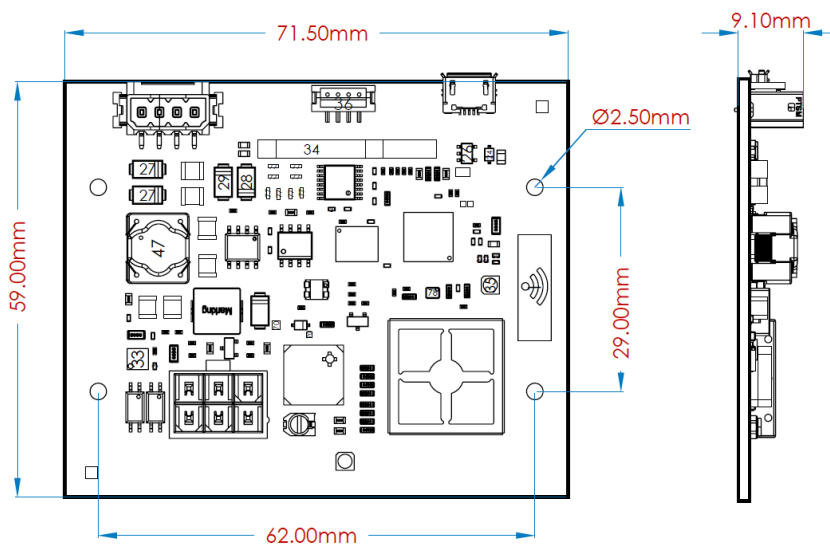

Connector Details and Pinout

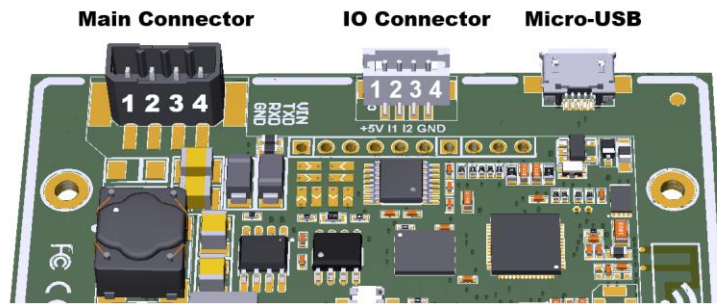

Main Connector	RS232 Mode	RS485 Mode
1	GND – Ground	GND – Ground
2	RX Input	B
3	TX Output	A
4	+VIN (+7 to +60 VDC)	+VIN (+7 to +60 VDC)

Connector Type: Phoenix Contact PTSM Series, **PTSM 0,5/4-HV-2,5-THR R32** (4-position, horizontal, THR)
Phoenix Contact Article No.: 1778573

Mating Connector Type: Phoenix Contact **PTSM 0,5/4-P-2,5** | **Article Number:** 1778858

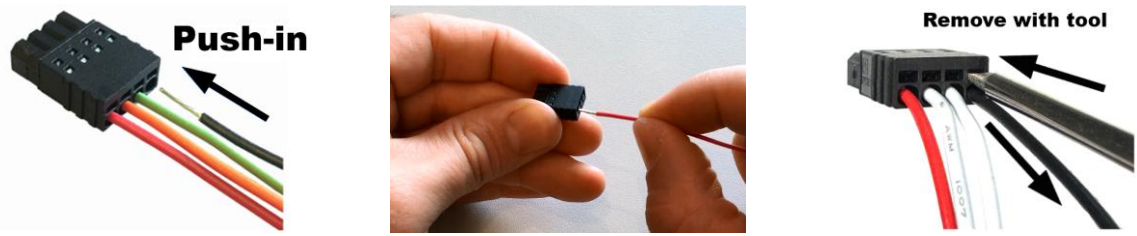

IO Connector	LED Mode	Output Mode	I2C Mode
1	+5VDC	+5VDC	+5VDC
2	LED1 cathode input	Output1	SCL – Clock
3	LED2 cathode input	Output2	SDA – Data
4	GND- Ground	GND	GND

Connector Type: JST ZH Series, **B4B-ZR-SM4-TF** (4-pin board-mount header)
Mating Plug Housing: JST ZH Series, **ZHR-4** | **Associated Crimp Contact:** JST ZH Series, **SZH-002T-P0.5**

RGB-LED

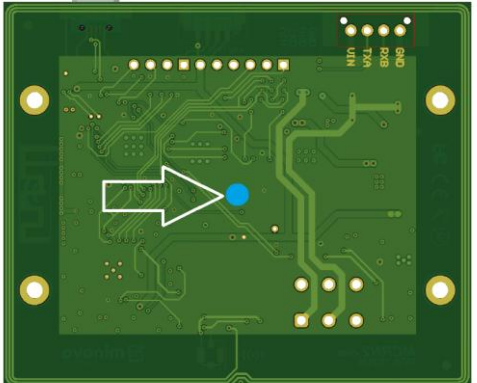

Ordering Code

Ordering Code	RS232	RS485	USB	Wi-Fi/BLE	Int. Ant
MCRN2-1100	✓		✓	Opt.	✓
MCRN2-1110		✓	✓	Opt.	✓

FCC Regulatory Conformance

Radiation Exposure Statement

This equipment complies with FCC radiation exposure limits set forth for an uncontrolled environment. This equipment should be installed and operated at a minimum distance of 20cm between the radiator and your body.

NOTE: This equipment has been tested and found to comply with the limits for a Class A digital device, pursuant to part 15 of the FCC Rules. These limits are designed to provide reasonable protection against harmful interference in a residential installation. This equipment generates uses and can radiate radio frequency energy and, if not installed and used in accordance with the instructions, may cause harmful interference to radio communications. However, there is no guarantee that interference will not occur in a particular installation. If this equipment does cause harmful interference to radio or television reception, which can be determined by turning the equipment off and on, the user is encouraged to try to correct the interference by one or more of the following measures:

- Reorient or relocate the receiving antenna.
- Increase the separation between the equipment and receiver.
- Connect the equipment into an outlet on a circuit different from that to which the receiver is connected.
- Consult the dealer or an experienced radio/TV technician for help.

FCC Part 15.19 Warning Statement- (Required for all Part 15 devices)

THIS DEVICE COMPLIES WITH PART 15 OF THE FCC RULES. OPERATION IS SUBJECT TO THE FOLLOWING TWO CONDITIONS: (1) THIS DEVICE MAY NOT CAUSE HARMFUL INTERFERENCE, AND (2) THIS DEVICE MUST ACCEPT ANY INTERFERENCE RECEIVED, INCLUDING INTERFERENCE THAT MAY CAUSE UNDESIRE OPERATION.

FCC Part 15.21 Warning Statement-

NOTE: THE GRANTEE IS NOT RESPONSIBLE FOR ANY CHANGES OR MODIFICATIONS NOT EXPRESSLY APPROVED BY THE PARTY RESPONSIBLE FOR COMPLIANCE. SUCH MODIFICATIONS COULD VOID THE USER'S AUTHORITY TO OPERATE THE EQUIPMENT.

Minova Technology GmbH

Lindenstraße 2
78628 Rottweil / Germany



info@minovatech.de
+49 (0) 741 348 51 564

The information provided in this datasheet is intended to describe the general characteristics and technical specifications of products manufactured by **Minova Technology GmbH**. It is subject to change without prior notice and does not constitute a guarantee or warranty of any kind. Minova Technology GmbH assumes no responsibility for any errors or omissions that may occur in this document or for the use of the information contained herein.

© 2026 Minova Technology GmbH. All rights reserved.